

# HC-D15-SL-PLBK - Housing brackets



1414667

<https://www.phoenixcontact.com/us/products/1414667>

Please be informed that the data shown in this PDF document is generated from our online catalog. Please find the complete data in the user documentation. Our general terms of use for downloads are valid.



Replacement single locking latch, plastic, for HC-EVO-D15....BK and HC-STA-D15....AL housings

## Commercial data

Item number	1414667
Packing unit	1 pc
Minimum order quantity	10 pc
Sales key	BF66
Product key	BF7APZ
Catalog page	Page 663 (C-2-2017)
GTIN	4055626031187
Weight per piece (including packing)	11.18 g
Weight per piece (excluding packing)	11.18 g
Customs tariff number	39269097
Country of origin	PL

# HC-D15-SL-PLBK - Housing brackets



1414667

<https://www.phoenixcontact.com/us/products/1414667>

## Technical data

### Product properties

Type	D15
Product type	Housing latches

### Material specifications

Material	PA
Locking latch material	PA

### Environmental and real-life conditions

#### Ambient conditions

Ambient temperature (operation)	-40 °C ... 125 °C
---------------------------------	-------------------

### Mounting

Assembly instructions	For HC-EVO-D15...BK housing
-----------------------	-----------------------------

# HC-D15-SL-PLBK - Housing brackets



1414667

<https://www.phoenixcontact.com/us/products/1414667>

## Drawings

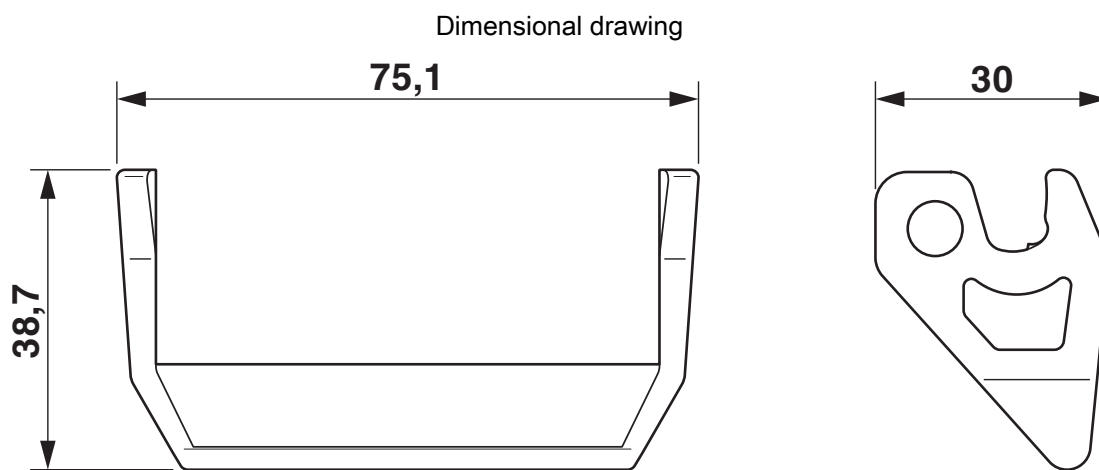

Dimensional drawing

# HC-D15-SL-PLBK - Housing brackets



1414667

<https://www.phoenixcontact.com/us/products/1414667>

## Approvals

To download certificates, visit the product detail page: <https://www.phoenixcontact.com/us/products/1414667>



**EAC**

Approval ID: RU C-DE.AI30.B.01102

# HC-D15-SL-PLBK - Housing brackets



1414667

<https://www.phoenixcontact.com/us/products/1414667>

## Classifications

### ECLASS

ECLASS-11.0	27440192
ECLASS-12.0	27440192
ECLASS-13.0	27440192

### ETIM

ETIM 9.0	EC002943
----------	----------

### UNSPSC

UNSPSC 21.0	39121400
-------------	----------

# HC-D15-SL-PLBK - Housing brackets



1414667

<https://www.phoenixcontact.com/us/products/1414667>

## Environmental product compliance

China RoHS	Environmentally friendly use period: unlimited = EFUP-e
	No hazardous substances above threshold values

Phoenix Contact 2023 © - all rights reserved  
<https://www.phoenixcontact.com>

Phoenix Contact USA  
586 Fulling Mill Road  
Middletown, PA 17057, United States  
(+717) 944-1300  
[info@phoenixcon.com](mailto:info@phoenixcon.com)